

USN

--	--	--	--	--	--	--	--	--	--



10ME/PM82

Eighth Semester B.E. Degree Examination, July/August 2021
Control Engineering

Time: 3 hrs.

Max. Marks:100

Note: Answer any FIVE full questions.

1.
 - a. Explain open loop and closed loop control system with an example for each type. (08 Marks)
 - b. What are the requirements of an ideal control system? (06 Marks)
 - c. Mention the characteristics of
 - i) proportional controller
 - ii) Integral controller
 - iii) Derivative controller (06 Marks)

2.
 - a. A thermometer is dipped in a vessel containing liquid at a constant temperature of θ_i . The thermometer has a thermal capacitance for storing heat as C and thermal resistance to limit heat flow as R . If the temperature indicated by the thermometer is θ_0 . Derive the transfer function of the system. (10 Marks)
 - b. With the help of circuit diagram, obtain transfer function of armature controlled D-C motor. (10 Marks)

3.
 - a. Reduce the block diagram as shown in Fig Q3 (a) using reduction technique and obtain $C(s)/R(s)$

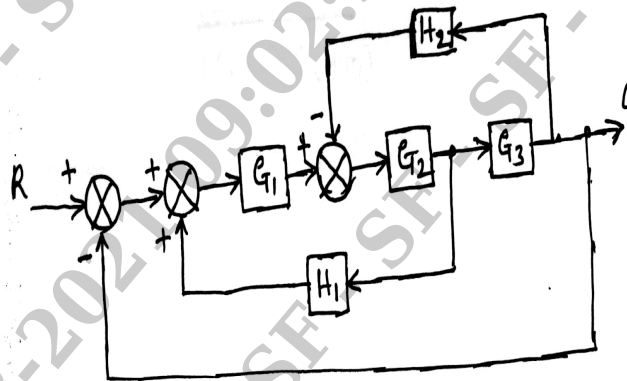

Fig Q3(a)

(10 Marks)

- b. Define following terms related to signal flow graph :
 - i) Source node
 - ii) Path
 - iii) Forward path
 - iv) Feedback loop
 - v) self loop
 - vi) Sink node. (06 Marks)

- c. State and explain Mason's gain formula. (04 Marks)

Important Note : 1. On completing your answers, compulsorily draw diagonal cross lines on the remaining blank pages.
 2. Any revealing of identification, appeal to evaluator and /or equations written eg. 42+8 = 50, will be treated as malpractice.



- 4 a. Derive an expression for the unit step response of first order system. (07 Marks)
- b. An unity feedback system has an open-loop transfer function $G(s) = \frac{K}{S(ST+1)}$
- i) By what factor amplifier gain K should be multiplied so that damping ratio is increased from 0.2 to 0.8.
 - ii) By what factor the time constant T should be multiplied so that the damping ratio is reduced from 0.6 to 0.3. (08 Marks)
- c. Investigate the stability of the system using R-H criterion having the following characteristics equation. (05 Marks)
- $$s^4 + 2s^3 + 3s^2 + 8s + 2 = 0.$$
- 5 Sketch the Nyquist plot for system with (20 Marks)
- $$G(s)H(s) = \frac{K}{s(s+2)(s+10)}.$$
- Calculate the range of K for stability.
- 6 Construct the Bode plot on a semi-log graph paper for a unity feedback system, whose open-loop transfer function is given by (20 Marks)
- $$G(s)H(s) = \frac{10}{s(1+s)(1+0.02s)}.$$
- Determine :
- i) Gain and phase cross over frequencies
 - ii) Gain and phase margin
 - iii) Stability of the closed loop system. (20 Marks)
- 7 Sketch the root locus for the system having (20 Marks)
- $$G(s)H(s) = \frac{K}{s(s^2 + 2s + 2)}.$$
- For what values of K the system is stable. Comment on stability.
- 8 a. What is system compensation? Explain briefly the (08 Marks)
- i) Series compensation
 - ii) Feedback compensation
- b. Explain with a sketch : (12 Marks)
- i) Lag compensator
 - ii) Lead compensator.

* * * * *